



## M-7068(D)

## M-7069(D)

4-channel Form A Relay Output and 4-channel Form C Relay Output Module

### Features

- M-7068(D)
  - 4 Form A and 4 Form C Signal Relay Output
  - 2000 VDC Intra-module Isolation
- M-7069(D)
  - 4 Form A and 4 Form C Power Relay Output
  - 3750 VDC Intra-module Isolation
- Dual Watchdog
- 4 kV ESD Protection
- Configurable Power-on Value Settings
- Configurable Safe Value Settings
- Wide Operating Temperature Range: -25 to +75°C



### Introduction

The M-7068 provides 4 Form A signal relay output channels and 4 Form C signal relay output channels, while the M-7069 provides 4 Form A power relay output channels and 4 Form C power relay output channels. Both include 8 LED indicators that can be used to monitor the relay output status, and options are provided that allow power-on and safe digital output values to be configured. 4 kV ESD, 4 kV EFT and 3 kV surge protection are also provided to enhance noise protection capabilities in industrial environments. The M-7068 is the ideal solution for small signal switching, while the M-7069 is the ideal solution for high power applications.

### System Specifications

Model	M-7068	M-7068D	M-7069	M-7069D
<b>Communication</b>				
Interface	RS-485			
Bias Resistor	No (Usually supplied by the RS-485 Master. Alternatively, add a tM-SG4 or SG-785.)			
Format	(N, 8, 1), (N, 8, 2), (E, 8, 1), (O, 8, 1)			
Baud Rate	1200 to 115200 bps			
Protocol	Modbus RTU, DCON			
Dual Watchdog	Yes, Module (1.6 Seconds), Communication (Programmable)			
<b>LED Indicators/Display</b>				
System LED Indicator	Yes, 1 as Power/Communication Indicator			
I/O LED Indicators	-	Yes, 8 LEDs as Relay Output Indicators	-	Yes, 8 LEDs as Relay Output Indicators
7-segment LED Display	-			
<b>Isolation</b>				
Intra-module Isolation, Field-to-Logic	2000 Vdc		3750 Vdc	
<b>EMS Protection</b>				
ESD (IEC 61000-4-2)	±4 kV Contact for each Terminal			
	±8 kV Air for Random Point			
EFT (IEC 61000-4-4)	±4 kV for Power Line			
	±2 kV for RS-485 Port Line			
Surge (IEC 61000-4-5)	±3 kV for Power			
<b>Power</b>				
Reverse Polarity Protection	Yes			
Input Range	+10 ~ +30 Vdc			
Consumption	1.6 W (Max.)	2.0 W (Max.)	2.1 W (Max.)	2.5 W (Max.)
<b>Mechanical</b>				
Dimensions (L x W x H)	123 mm x 72 mm x 35 mm			
Installation	DIN-Rail or Wall Mounting			
<b>Environment</b>				
Operating Temperature	-25 to +75°C			
Storage Temperature	-40 to +85°C			
Humidity	10 to 95% RH, Non-condensing			

### Applications

- Building Automation
- Machine Automation
- Remote Diagnosis
- Factory Automation
- Remote Maintenance
- Testing Equipment

### I/O Specifications

Model	M-7068	M-7068D	M-7069	M-7069D
<b>Relay Output</b>				
Channels	8 (Form A x 4, Form C x 4)			
Relay Type	Signal Relay		Power Relay	
Form A	Contact Rating	2 A @ 30 Vdc 0.24 A @ 220 Vdc 0.25 A @ 250 VAC		6 A @ 35 Vdc 6 A @ 240 VAC
	Min. Contact Load	10 mA @ 20 mV		100 mA @ ≥ 12 V
	Contact Material	Silver Nickel, Gold-covered		Silver Cadmium Alloy
	Operate Time	3 ms (typical)		5 ms (typical)
	Release Time	4 ms (typical)		1 ms (typical)
	Mechanical Endurance	10 <sup>8</sup> ops		30 X 10 <sup>6</sup> ops
	Electrical Endurance	2 X 10 <sup>5</sup> ops		1 X 10 <sup>5</sup> ops
Form C	Contact Rating	2 A @ 30 Vdc 0.24 A @ 220 Vdc 0.25 A @ 250 VAC		5 A @ 30 Vdc 5 A @ 250 VAC
	Min. Contact Load	10 mA @ 20 mV		10 mA @ ≥ 12 V
	Contact Material	Silver Nickel, Gold-covered		Silver Nickel Alloy
	Operate Time	3 ms (typical)		5 ms (typical)
	Release Time	4 ms (typical)		2 ms (typical)
	Mechanical Endurance	10 <sup>8</sup> ops		15 X 10 <sup>6</sup> ops
	Electrical Endurance	2 X 10 <sup>5</sup> ops		1 X 10 <sup>5</sup> ops
Surge Strength	2000 Vdc		4000 Vdc	
Power-on Value	Yes			
Safe Value	Yes			

## Internal I/O Structure

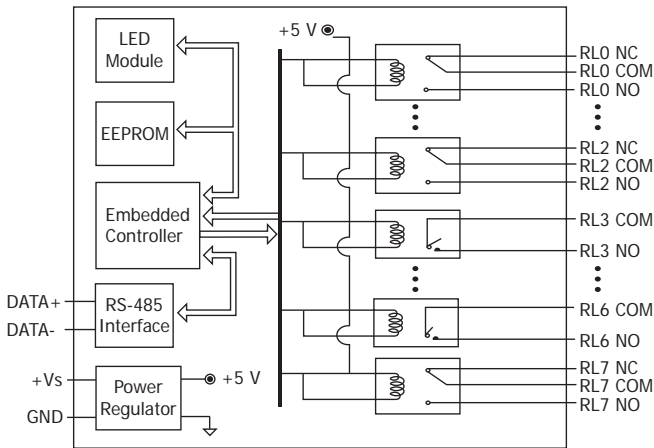

## Pin Assignments

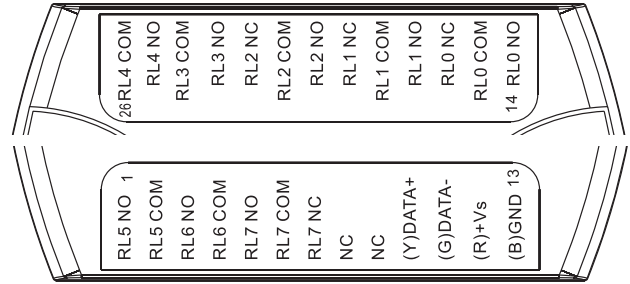

## Wire Connections

Relay Output	ON State Readback as 1	OFF State Readback as 0
Form A Relay in RL3 ~ RL6		
Form C Relay in RL0 ~ RL2 and RL7		

## Ordering Information

<b>M-7068 CR</b>	4-channel Form A Signal Relay Output and 4-channel Form C Signal Relay Output Module (Gray Cover) (RoHS)
<b>M-7068D CR</b>	M-7068 with LED Display (Gray Cover) (RoHS)
<b>M-7069 CR</b>	4-channel Form A Power Relay Output and 4-channel Form C Power Relay Output Module (Gray Cover) (RoHS)
<b>M-7069D CR</b>	M-7069 with LED Display (Gray Cover) (RoHS)

## Accessories

	tM-7520U CR	RS-232 to RS-485 Converter (RoHS)
	tM-7561 CR	USB to RS-485 Converter (RoHS)
	I-7514U CR	4-channel RS-485 Hub (RoHS)
	SG-3000 Series	Signal Conditioning Modules for Thermocouple, RTD, DC Voltage, DC Current and Power Input Transformers